



AVK SURFACE BOX H-4056 MD-KU

80/31
004

Fixed height
Surface box for distribution valves
Standard lid inscription: AVK W

Type

- H-4056 MD-KU
- Round synthetic lid
- Round top surface box

Features

- Lightweight, user-friendly, silent and maintenance free
- 100% recyclable and significantly less use of resources compared to traditional materials
- Manufactured out of high grade recycled materials
- Ribs in housing ensure optimal fixation in road foundation
- Selected materials for housing and lid ensure easy opening at all times
- Heat resistant to max. 250 °C
- Suitable for low-temperature applications
- Locking clip around the bolt ensuring lid will stay in its place
- Lid material discourages thieves; no value in stealing
- Synthetic lid enables signal transmission
- C250 load bearing capacity

Optional

- Various colours and lid inscriptions possible
- Available as lockable version making the surface box tamperproof

Standards

- Design derived from DIN 4056
- DVGW VP 310-2

Accessories

- Support tile I



Expect... **AVR**

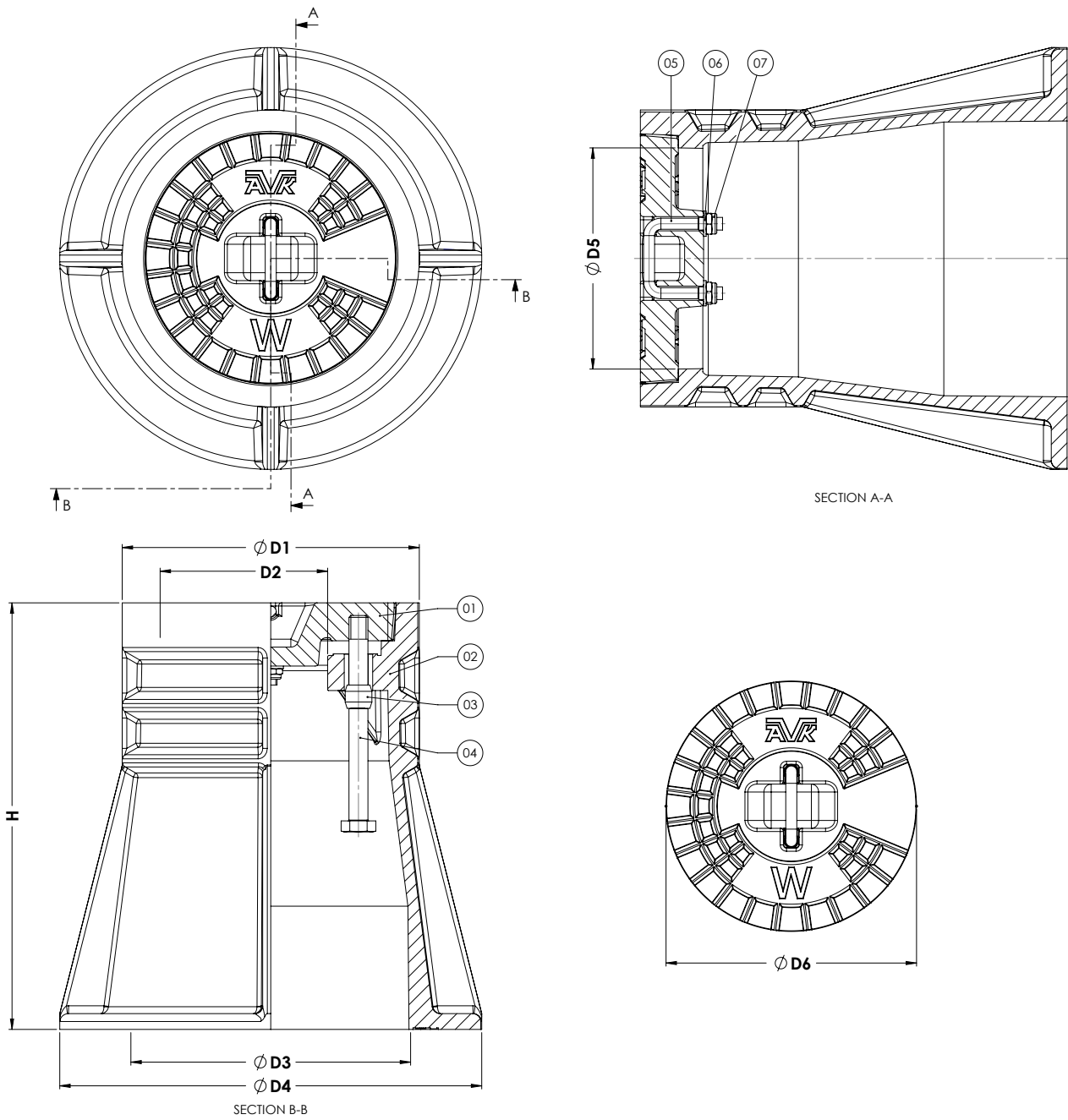

Component list

1. Lid	PP 40%GF
2. Housing	PA+
3. Locking clip	PP
4. Notched bolt M12x130 hexagon head	A2-70
5. Crossbar	A2
6. Washer M8	A2
7. Prevailing torque nut M8	A2

Reference nos. and nominal dimensions

AVK ref. nos.	D1 mm	D2 mm	D3 mm	D4 mm	D5 mm	D6 mm	H mm	Weight box in kg	Weight lid in kg	Total weight in kg
80-31-0040009	188	106	177	267	140	159	270	2.1	0.6	2.7

For other variants different item numbers apply
Dimensions are subject to tolerances