



## AVK SURFACE BOX H-4056-2 HD-GG

80/39  
000

Fixed height  
Surface box for distribution valves  
Standard lid inscription: W

### Type

- H-4056-2 HD-GG
- Round cast iron lid
- Round top surface box

### Features

- Lightweight, user-friendly, silent and maintenance free
- 100% recyclable and significantly less use of resources compared to traditional materials
- Manufactured out of high grade recycled materials
- Ribs in housing ensure optimal fixation in road foundation
- Selected materials for housing and lid ensure easy opening at all times
- Heat resistant to max. 250 °C
- Suitable for low-temperature applications
- Ideal solution in combination with 3S Antriebe products: [www.3s-antriebe.de](http://www.3s-antriebe.de)
- C250 load bearing capacity

### Optional

- Spring around bolt ensuring lid will stay in its place
- Various colours and lid inscriptions possible
- Available as lockable version making the surface box tamperproof

### Standards

- Design according to DIN 4056-2
- DVGW VP 310-2
- DVGW approval, certificate DW-6430CQ0201



Expect... **AVR**

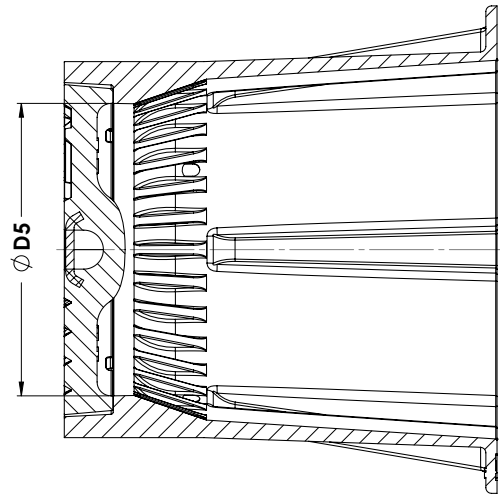
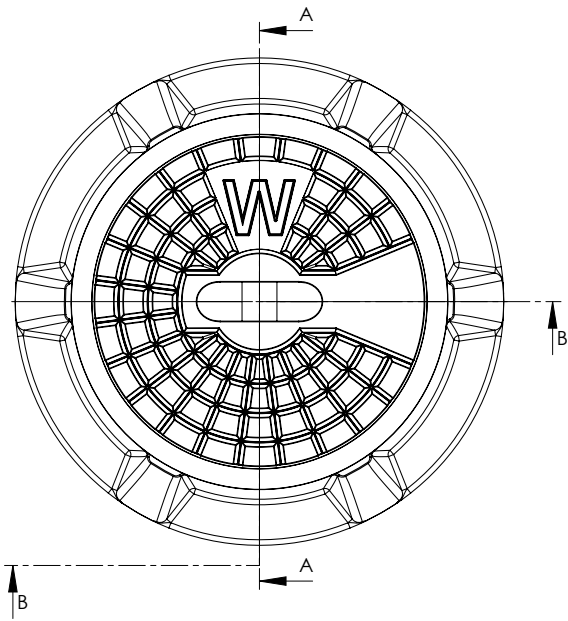

SECTION A-A

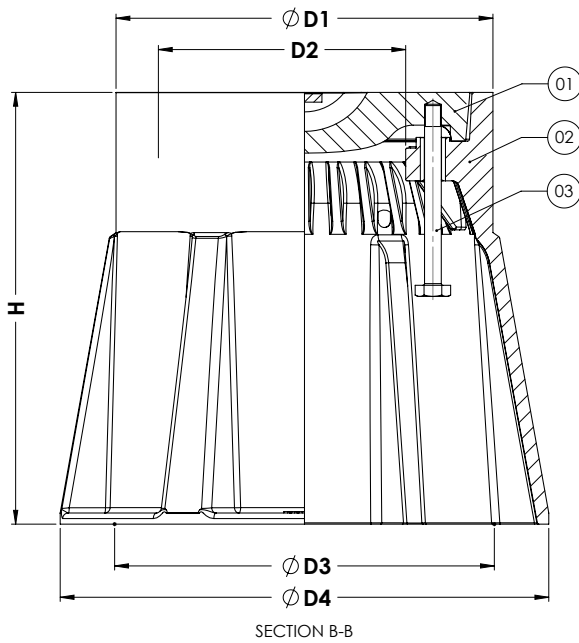

SECTION B-B

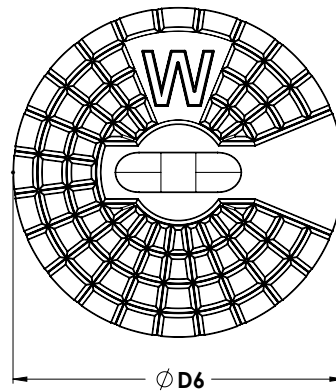

**Component list**

1. Lid	EN-GJL-200
2. Housing	PA+
3. Bolt M12x130 hexagon head	A2-70

**Reference nos. and nominal dimensions**

AVK ref. nos.	D1 mm	D2 mm	D3 mm	D4 mm	D5 mm	D6 mm	H mm	Weight box in kg	Weight lid in kg	Total weight in kg
80-39-0000000	270	177	272	350	210	237	310	4.0	8.1	12.1

For other variants different item numbers apply  
 Dimensions are subject to tolerances